



Miniature version
of the Type 12

Sensor Head Type:
Optical

PRODUCT DATA SHEET

Type 13 Sensor Head

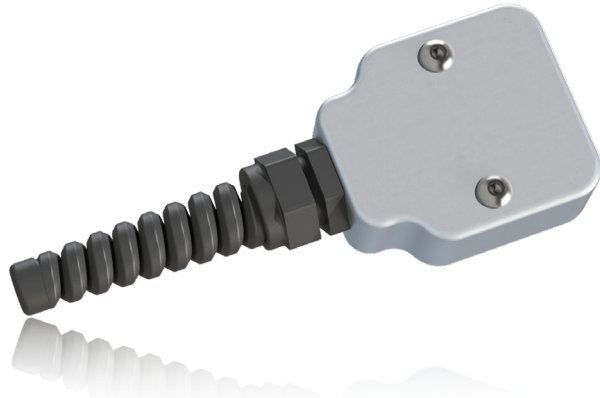

TECHNICAL SPECIFICATION

Environment Conditions	
Operating Temperature	+10°C to +50°C +50°F to +122°F
Shipping & Storage Temperature	+5°C to +70°C +23°F to +158°F
Protection Class	IP54
Sensor (Optical)	
Type	Infrared Optical
IR Wavelength	970nm
Visible Aiming Beam	Narrow angle orange LED
Housing	Machined Aluminium (Anodised Titanium Grey)
Cable length	1.25m

DIMENSIONS

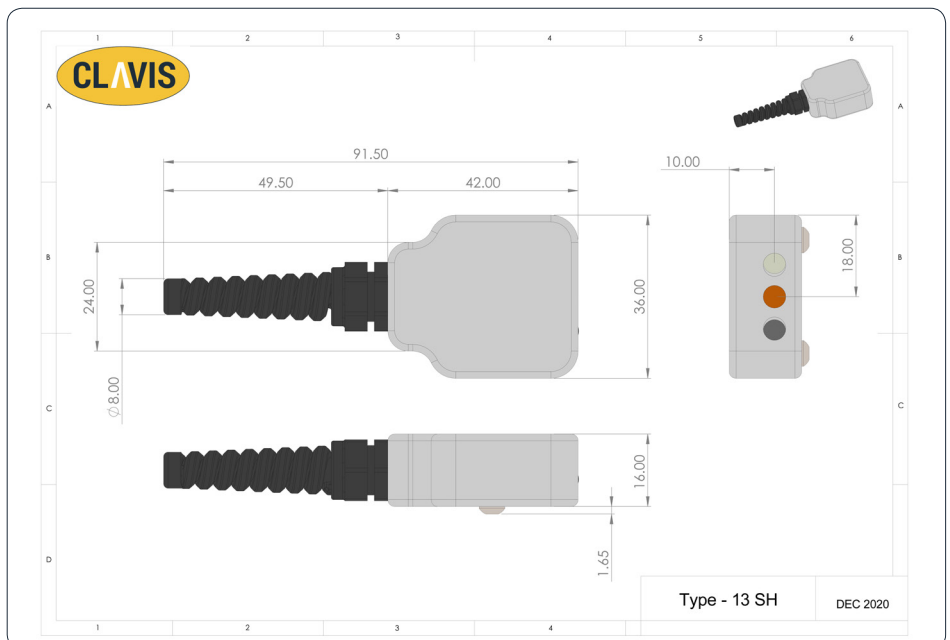

IDS

**IDS INTEGRATED
DISPLAY SYSTEMS LTD**

Unit 4A New York Way
New York Industrial Park
Newcastle upon Tyne
NE27 0QF, UK

admin@clavis.co.uk
t: + 44 (0) 191 262 7869

www.clavis.co.uk